

# LT-1 Ignition System - Getting to Know the Opti-Spark

Understanding and Modifying This Much-Maligned Ignition System

By Ray T. Bohacz

Editor's Note: Way back in March of 1998, GMHTP ran "Opti-Spark" by Ray Bohacz, an engineering-level dissection of GM's Opti-Spark distributor. This evolutionary ignition component was a bridge between traditional distributors and the DIS-type, coil-on-plug systems that we know and love today. Unfortunately, LT1 owners have had long-term reliability problems with the Opti-Spark, and even though it has been around for 11 years now, many enthusiasts are still in the dark when it comes to identifying, troubleshooting, or upgrading them. The first half of this story is a similar version of the one Ray wrote in 1998; the last half focuses on model identification, trouble signs, and new technology that will allow Optis to last longer and perform better.

To be worthy of the famous LT1 designation the latest rendition of this engine needed to exceed the pre-emissions version's power generation while meeting today's demanding standards to be considered world-class. Specific mass, size, fuel consumption, emissions, start-ability and torque-band-width all needed to be improved over the L98 engine that it replaced--all while surpassing previous reliability levels.

Early on in the LT1's development the design team recognized the inherent deficiencies of the then-current L98 and the pitfalls it would cause in arriving at their goals. To this cause the LT1 employed advanced theories such as reverse-flow engine cooling and a gear-driven water pump. The Opti-Spark first appeared on the 1992 Corvette and then progressed to the fourth-generation F-body in 1993. The same ignition is also found in the full-size B-body cars when they switched to LT1 power for the 1994 model year. During the Opti-Spark's reign there were three distinct versions of the distributor, but they all functioned in the same manner. The differences were found in the drive mechanism along with the design of the housing and vent system.

## Time Versus Angle-Based Ignition

Prior to the Opti-Spark most conventional ignition systems referenced the delivery of the spark through a time-based method. These systems functioned on a prescribed time-delay period after passing a reference point that was usually an interrupt signal from a magnetic reluctance sensor, more commonly known as a pick-up coil. In contrast, the Opti-Spark uses multiple optical sensors working in conjunction with a two-track slotted disk to have the ability to identify in one-degree increments the position of the crankshaft. This is done by incorporating both a high-resolution outer track of 360 slots and a low-resolution inner track with eight varying-width slots that identify each cylinder.

By recognizing both the leading and falling edges of the high-resolution signal, the ECM knows the position of the crankshaft within one degree. A light beam is created by dual LEDs and photo transistors and reads the low-resolution slot signals at TDC for each cylinder. The number of high-resolution pulses observed prior to reaching the falling edge of a low-resolution slot is the method used for identification. The light passing through each of the slots generates a 5-volt transistor-to-transistor logic signal that is recognized by the ECM.

Using both the leading and falling, commonly referred to as the trailing edge of the square wave output generated by the high-resolution sensor, effectively encodes 720 high-resolution edges to keep track of the crankshaft's position in lieu of the four acknowledged positions that a conventional ignition is referenced from. By comparison, a magnetic reluctance sensor (unless equipped with an ancillary signature pulse) has no knowledge of which cylinder is firing. But more importantly, it has 45 degrees of distributor rotation that is not recognized and is unaccountable.

1. The Opti-Spark ignition system breaks tradition in a number of unique ways beyond its optical triggers. The following technology is represented in this design:
2. The combination of two systems in one. A high-resolution engine timing system and a low-energy secondary distribution network.
3. The ability for the ECM to have total control over the ignition timing through an angle-based spark advance function along with the ancillary control of altering the cranking start-up ignition timing based on the ambient air temperature.
4. Robust reductions in spark scatter during instantaneous transient acceleration of 10-rpm-per-millisecond or greater intervals in comparison with time-based methodology.
5. The ability to benefit from a more aggressive timing curve without entering the spark knock zone.
6. A large cap design with a widened rotor tip, allows for all of the secondary voltage to be delivered radially without employing a large rotor tip clearance. This reduction in rotor tip clearance also pays dividends in decreased radio frequency interference generation.

7. Individual cylinder timing and knock retard capabilities.
8. Accurate drive positioning directly from the front of the camshaft.
9. No need for mechanical timing adjustment.

### **Opti-Spark Features**

The LT1 ignition system could actually be referred to as a hybrid that is a cross between a time-based conventional ignition and a corresponding duration-configured distributorless design. Prior to the development of the Opti-Spark the exact position of the crankshaft was never recognized by the ECM, that data was not available. The input of data in one-degree increments of crankshaft rotation into the ECM's programming now allows for more accurate control of engine functions. In a standard L98 ignition, which is an electronic-spark-timing high-energy system, control of the spark advance curve is handled by the tables in the PROM once an engine speed of 400 rpm was surpassed. Below that rpm the control of the ignition timing was independent of the ECM and was a function of the module and the installed position of the distributor. Testing by GM proved that at an ambient temperature of -35 degrees C, the time-based ignition would have a start time of approximately four seconds while the angle-based LT1 would fire in 1.5 seconds. This is the result of knowing the exact crankshaft position along with the ability to vary the ignition timing on crank as a function of coolant temperature.

To a calibration engineer concerned with meeting EPA cold-start emissions standards this is invaluable. When the engine is cranking, fuel is being administered at a rate of inject pulses twice as often as it is during engine run along with substantially longer pulse widths. The more fuel injected during crank, the higher the hydrocarbon emissions and the longer it will take the catalytic converter to light off once combustion starts. By decreasing the cold start crank time, the extremely critical first two minutes of emissions output is greatly reduced. This is a major concern during the EPA cold start test cycle.

A combination of a decreased rotor gap, along with the use of a conductive ink to route the spark path in the plastic encapsulated distributor cap, allows for minimal voltage losses and longer burn times at the plug from the increased available energy. Burn times are referenced in degrees of crankshaft rotation that the ignition system has the ability to keep the spark plug ignited. Any gains are extremely desirable and increase the conversion of chemical to mechanical energy. Energy losses that are absorbed by the larger necessary rotor gap in a conventional distributor consumes a portion of the coil's output, leaving less voltage to bridge the gap of the spark plug.

With the ECM capable of using input data sensors to calculate the required spark advance curve, the start of the coil saturation period is converted from a time-based to angular function. The timing signal that begins with coil charging and ends with the secondary discharge of the ignition coil can now be interfaced with crankshaft position to offer individual cylinder timing control and knock recognition. Reading the leading (rising) edge of the low-resolution optical signal along with dual knock sensors (some models), the ECM is able to identify detonation on individual cylinders and offer timing correction to those in need.

Spark scatter is defined as a variation between the actual timing signal and the value commanded by the ECM. It is also known as cycle-to-cycle and cylinder-to-cylinder timing variation. This can occur in a number of distinct scenarios, but scatter is the most common during transient instantaneous acceleration of the engine. It is a result of a stack-up of tolerance in the distributor drive gear and changes in timing chain tension that are caused by localized acceleration between cylinder events.

Spark scatter detracts from the aggressiveness of the programmed advance curve. This is because an engine with increased scatter values tends to drift toward the spark knock zone during rapid acceleration. Due to the variation in timing, an additional buffer needs to be built into the spark calculations on conventional distributors. By reducing timing error not only can additional advance be used, but the effect that scatter has on power, fuel economy, and emissions is minimized. Ignition timing error is most apparent during crank when the slow speed of the engine accentuates the non-circular motion of any internal combustion engine. Ignition variation during this time can be skewed up to 30 degrees with a conventional distributor. With the Opti-Spark the timing variation is a maximum of one degree of error.

Due to its unique installation location and other design features, the LT1 ignition offers no mechanical timing adjustment. The Opti-Spark not only paid dividends in decreased assembly time during engine manufacturing, but also removes the inherent tolerance that a mechanically adjustable distributor creates during engine build procedures and infield service.

### **Same System, Different Look**

Common with many aspects of the automobile industry, the Opti-Spark endured a few evolutionary changes during its six-model-year run. The changes were not in how it operated, but to the drive mechanism, housing, and vent system.

All Opti-Spark systems have a removable distributor cap that allows access to the rotor. According to our sources at Jay Fisher Pontiac-GMC who specialize in modifying GM EFI cars, there are no service parts offered for the early design. The later-style allows replacement of the cap and rotor as a service item, but keep in mind that to access these components the water pump needs to be removed. As good as the Opti-Spark is, routine maintenance is not one of its strong points due to its location.

Early Opti-Spark systems had a tendency to collect moisture that would interfere with the function of the optical sensor and cause the engine to run very poorly. This condition would often induce cross- and misfire similar to a cracked distributor cap on a conventional ignition. Two distinct faults were at work when this occurred. The first was inaccurate primary interrupts from the moisture affecting the optical sensor's ability to clearly define the leading and falling edges of the 360-slot wheel. The second was more rudimentary. Electricity taking the path of least resistance, the high-energy secondary voltage would sooner follow the moisture down into the cap than bridge the spark plug under cylinder pressure. The high voltage would burn through the rotor or the slotted wheel, stopping the engine in its tracks.

To eliminate this problem, later designs incorporated a more efficient venting system that pulled air through the distributor housing from the throttle body. This was supposed to eliminate once and for all the moisture issue.

Other changes were made over the years to the engine-side of the housing and the size and attachment of the drive mechanism. Due to this there are three different timing case covers used on LT1 engines. Abe Bergian, motorsports service manager at Jay Fisher Pontiac-GMC, explained that the 1992 to 1994 versions of the Opti-Spark on both F- and Y-cars had no vent and used the timing case cover with a small distributor drive hole. 1994 B-cars used a new timing case and companion Opti-Spark that had increased venting, a serviceable cap and rotor, and a new-style drive attachment to the camshaft. This style was then switched to the F- and Y-cars for the 1995 model year. With the arrival of OBD-II for 1996, the timing case was again modified to accept a crankshaft sensor for misfire diagnostics but the Opti-Spark was unchanged. The older-style unvented design can be updated to the final version but would require a new-style timing case, Opti-Spark distributor, and changes to the cam drive mechanism. In addition, a longer dowel pin needs to be installed in the camshaft to drive the distributor. The first iteration used a traditional short Chevrolet cam dowel pin.

Within the ranks of the LT1/LT4 faithful a love-hate relationship has been established with the Opti-Spark. Some owners have experienced a rash of continuous failures while others have seen the system function perfectly for 200,000 miles in taxicabs and police cars. Both the author and GMHTP could not find any reason for the repeated failures some experience. The question is often posed to GMHTP for a way to remove the Opti-Spark and convert to another-style ignition system. This of course can be accomplished with the use of an aftermarket ECU such as ACCEL's excellent Generation 7.0 DFI that is configured to use a crankshaft trigger. But if the retention of the GM engine management system is desired, the use of the Opti-Spark is mandatory. Fortunately for LT1 aficionados two new products, the LTCC from Ramchargers and the DynaSpark from Dynotech Engineering Inc, provide a welcome alternative for those torn between continuously buying OEM GM Optis or converting to a stand-alone engine management system (See sidebars)

In conclusion, it is the author's opinion that the Opti-Spark is an excellent design that has been a victim of misunderstanding and poor mechanical procedures. There have also been reports of oil leaks into the distributor and this is usually the result of neglecting to change the seals in the timing cover when a cam swap is done. Today's tight-tolerance lip seals should be changed whenever the timing case cover is removed, but they often are put back into service and start to leak shortly after re-installation.

At GMHTP we hope that this has given you a newfound respect for this special ignition system. It offers features and benefits that allow the stunning performance of the LT1 engine that up until now have not been told.

### **DynaSpark: Opti-Spark Made Reliable**

The DynaSpark was designed to increase distributor reliability over an OEM Opti-Spark--which meant redesigning many of the external and internal components. The case is manufactured entirely of billet T-6061 aluminum plate stock for increased structural rigidity under extreme heat and cold. It is anodized red for two reasons--corrosion resistance from the elements and aesthetics. A deeper optical sensor mounting pocket was used to facilitate air circulation around the sensor for more effective sensor cooling. This greatly adds sensor life and accuracy. It is engineered to eliminate the need for the OE, white rinite insulator, which also eliminates one entire leak-prone perimeter seal entirely. The bearing bore provides a press fit for the bearing, which gives improved bearing support and provides a better foundation for higher rotor rpm capability. Internal component mounting boss holes are now blind as opposed to the leak-prone, OE pass-through mounting holes. The case perimeter now has a provision for a captured rubber, high temp O-ring, instead of the fluoro-silicone, leaky OE piece.

The bearing is now held securely in place by a hardened steel snap ring that provides a full 360 degrees of bearing retention surface area, as opposed to the OE twin-screw, stamped bearing retainer that rusts heavily, breaks frequently and provides only 40 percent of bearing retention surface area. The DynaSpark has its own semi-permanently sealed electrical connector harness tower that eliminates the leaky OE distributor connector entirely. The distributor drive cavity is now sealed to the timing chain cover with a rubber, high-temp O-ring to eliminate water/moisture intrusion into the backside of the case.

In case of distributor drive seal failure in the timing chain cover, oil cannot get forced internally into the case--thanks to a weep hole in the bottom of the distributor drive cavity that allows the oil to escape without contaminating the distributor housing.

The entire case is now cross-vented, instead of the plug-prone localized venting of the OE unit.

A modified distributor cap and voltage insulator enhances and improves cross-flow cap venting (which eliminates crossfire/misfire). Other features include a riveted rotor contact, a lightened rotor, heavier duty, stainless steel rotor mounting screws, and a semi-permanently sealed cap that must hold a 15-inch vacuum for 10 minutes before being allowed to "pass" for shipment. The entire rotating assembly is spin balanced and the rotor drive is correctly and accurately indexed to the #1 cylinder. Also of note, the electrical harness is now integral with this distributor and it comes complete with the new revised vacuum harness.

Also, Dynotech Engineering is working on two other projects: an upcoming Gen. I distributor for the '92-94 LT1s will share the same upgraded internal components and refinements of the Gen. II model. And the "Gen. III" distributor will be rotor-less and capable of 8500 engine rpm. The Gen. III is designed to work with the LTCC and individual LS1/LS6 ignition coils and will have all of the same improvements as the Gen. I and II, but with a billet aluminum cap in place of the OE plug wire cap and a lightweight reluctor wheel support. Owners of the Gen. I and II DynaSpark Distributors can always upgrade their current unit at a later time to the Gen. III unit by purchasing the "high rpm kit upgrade", which will allow them to utilize individual ignition coils and the LTCC. You can view the DynaSpark at [www.dynotech-eng.com](http://www.dynotech-eng.com).

### **LTCC: Opti-Spark Alternative**

The LTCC (LT1 Coil Conversion) grew from the need for a high-energy ignition system for the LT1 that did not use the distributor section of the Opti-Spark. The optical portion is reliable and is needed to keep the stock PCM happy. By using the Opti-Spark Hi Resolution and Low Resolution signals to feed the LTCC, the interface can decode which cylinder is being fired by the PCM and direct the timing signal (EST) to the appropriate coil. The LTCC also calculates its own dwell (coil charging time) and can begin charging the next coil in the firing order before firing the current coil. This allows full spark power at very high rpm. The LTCC can be run to 8000 rpm, much higher than most anyone runs an LT1. For high rpm operation (>6000 rpm), it is a good idea to remove the rotor from the Opti-Spark as it tends to shatter.

The LTCC system consists of an interface unit and plug-in wiring harness. Other than connecting to 12 volts to feed the coils and the EST wire, all connections are direct plug-in using OEM weatherproof connectors. The LTCC features a spark-based rev limiter (2 stage) and a timing retard that has built in curves for turbo, N2O, and supercharger applications. Both the retard and rev limiter can be enabled full-time or triggered. The LTCC has a trigger wire that can be configured to activate the second rev limiter stage or the timing retard.

In addition to the LTCC kit, the user needs to obtain 8 LS1 coils, plug wires and a way to mount the coils.

The wide array of header styles, valve cover dress-ups, and turbo systems has made the design of universal coil brackets a challenge. As of this date no truly universal bracket is available. Installations have been done on top of the intake plenum, and even on the frame rail (race application). The interface is a gasket-sealed aluminum box and can be mounted underhood. See the LTCC at [www.bailey-eng.com](http://www.bailey-eng.com)

### **Is Your Opti-Spark Failing?**

LT1 owners have dealt with the Opti-Spark distributor for 11 years now, but there is still much confusion regarding the causes and symptoms of a failing unit. Tapping into the PCM with a scan tool is a good way to start, but sometimes no codes will be set. Before diving into the Opti-Spark, be sure to verify that your grounds are good and the coil and wires are not the source of the problem, as they are much easier to change.

Symptoms:

- \* Car suddenly dies and won't restart
- \* Starts but immediately dies
- \* Extended cranking to start
- \* Rough idle
- \* Sputtering
- \* Backfiring
- \* Trouble reaching higher rpm
- \* Black smoke from exhaust
- \* Poor performance with car warmed up
- \* Weak plug wire spark
- \* Codes 16, 36, and 42 may be set

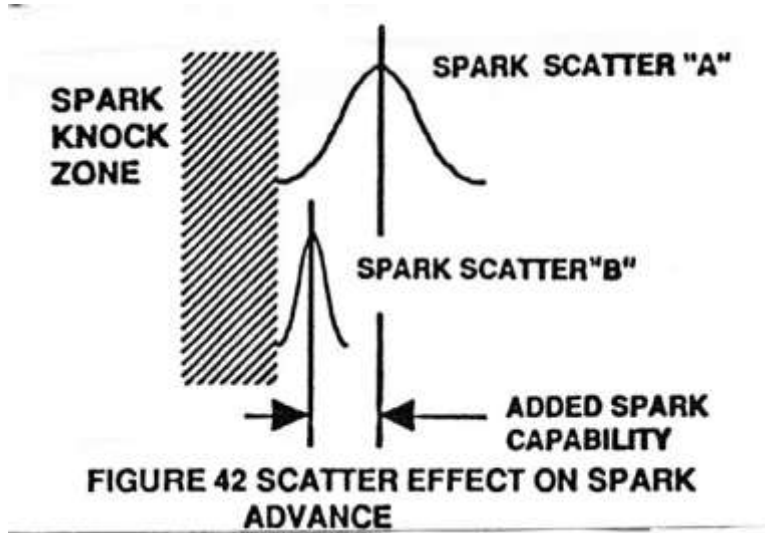

LT-1 Ignition System - Getting to Know the Opti-Spark

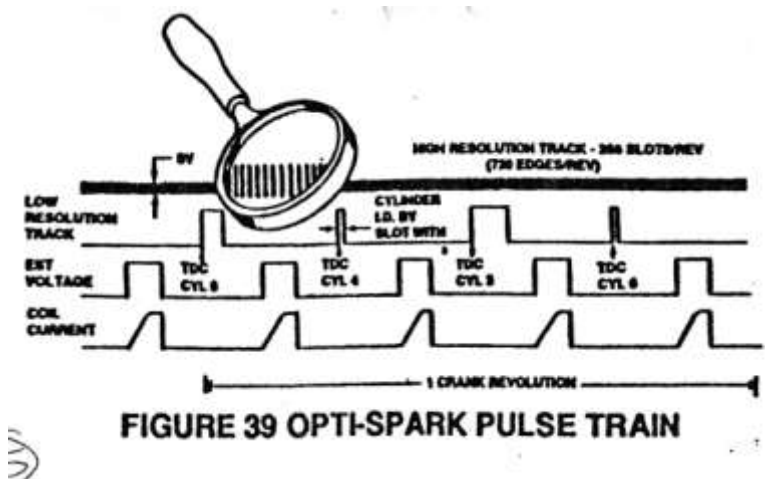

Identified as a "pulse train", both the high- and low-resolution signals along with the EST pulse and coil discharge can be viewed as they occur during one cylinder event. Note the signature pulses that are created by the low-resolution track to identify each cylinder in the firing event.

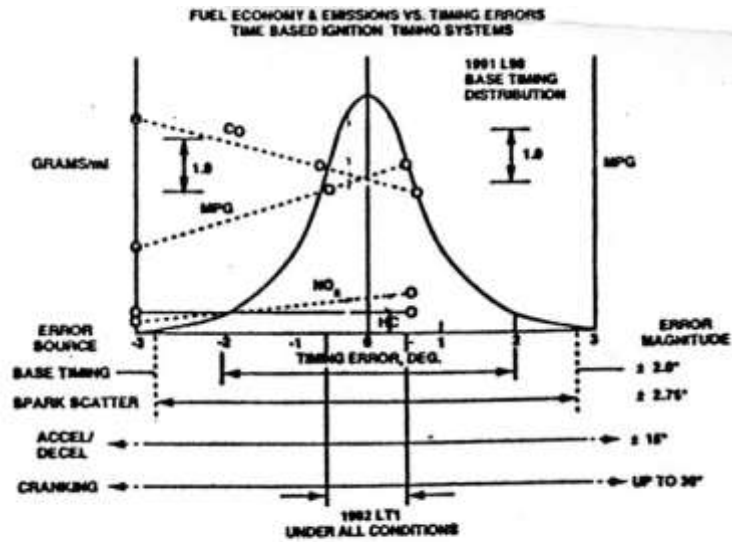

**FIGURE 38 EFFECT OF TIMING ERRORS**

Graphing the spark error in time-versus-angle-based ignition systems readily shows the accuracy of the Opti-Spark.

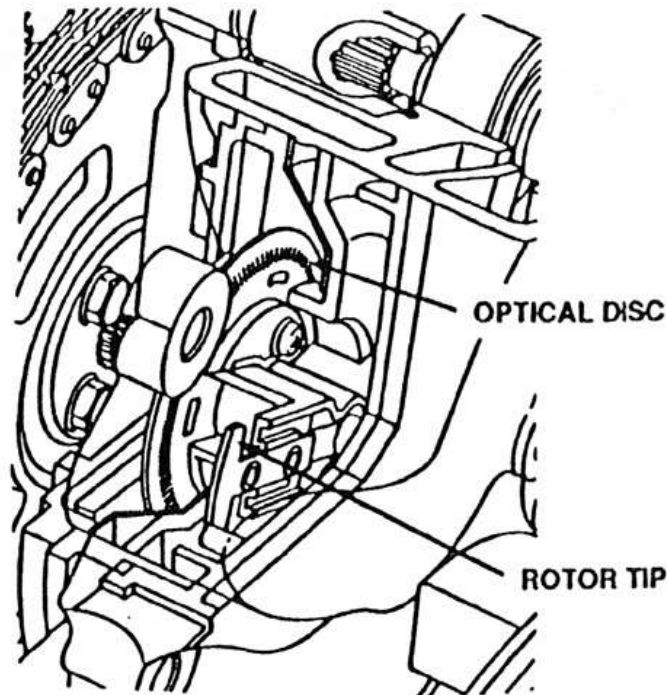

**FIGURE 37 OPTI-SPARK CONFIGURATION**

The laser cut stainless-steel optical disk and rotor tip, and how they interface with the rest of the distributor, are plainly seen in this illustration.

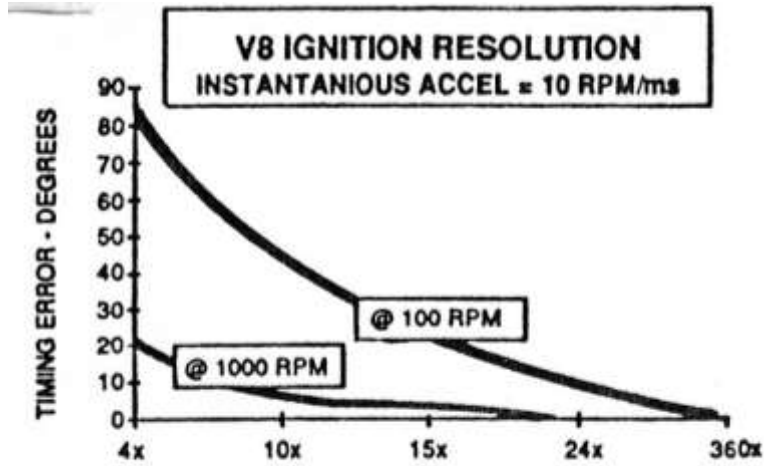

**FIGURE 41 ECM REFERENCES/REVOLUTION**

Timing error during instantaneous acceleration of the engine is a major contributor to a loss in power and a rise in emissions. This chart shows the potential for timing error with conventional time-based ignitions. Note the substantial increase in error at low rpm.

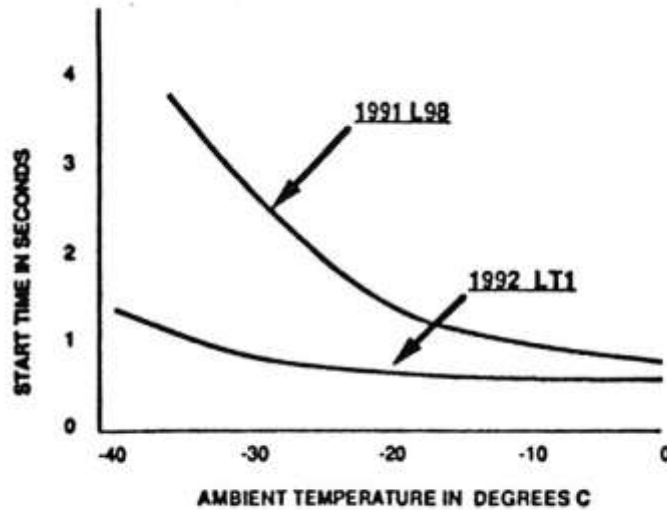

**FIGURE 46 COLD START PERFORMANCE**

Start-ability is an engineering term for how quick an engine transitions from crank to run. Note the Opti-Spark's indifference to temperature reductions in relation to start time.



The spark knock zone is identified as the area where abnormal combustion occurs when prompted by excessive spark scatter. Curve A represents the proximity of maximum spark advance with time-based ignitions. With these systems, the necessity of leaving a broad buffer to not allow the engine to enter the spark knock zone during timing variations becomes apparent. Curve B is the area occupied with angle-based Opti-Spark ignition. The minimal scatter produced by this system allows for aggressive timing curves plotted to the edge of the SKZ.



The wide-tipped rotor is held on by two recessed Torx-head screws.



This is a later style, serviceable cap. It is identified by the small vent tube located in-between the secondary lead mounting points.



All Opti-Spark distributors use an encapsulated plastic distributor cap to protect the conductive ink that transfers the high-voltage to the spark plug wires from the rotor.



This is an old-style design. Note the small drive mechanism in the center of the distributor.

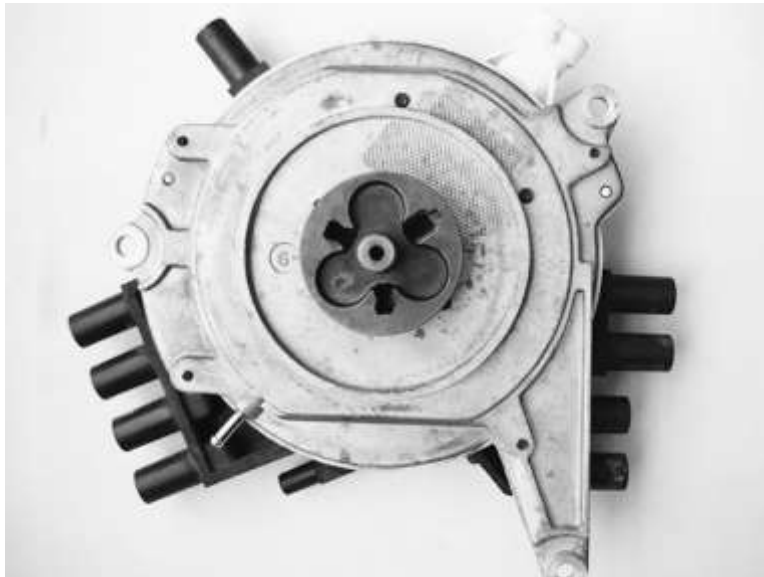

The revised version has a larger cam drive mechanism and an additional metal vent on the case of the distributor.



A first-generation timing cover. Note the small hole in the center to drive the distributor.



The OBD II-style case has a mounting boss for the crank sensor at the bottom of the casting.



This timing case is for an interim year. It accepts the large drive mechanism but does not have a provision for the crank sensor.